

We can make
a classic
even better!



The WEDO® kick step

The original – Made in Germany. Practical and unchanged for over 30 years. Exhibited in Berlin's Museum of Things. The untiring employee in virtually every supermarket. Indestructible and backed by a 10-year warranty. Actually unsurpassable!

We do it

STEP is now
SUPERSTEP!

Our ambition

1. Enhance product safety even further.
2. Improve the ecobalance.
3. Conserve resources.

To achieve these three goals, we have spent the last few years tinkering, developing, designing, discussing, deciding and ultimately making major investments. We commissioned new machines and tools, optimized the prototypes and, like all safety products at WEDO®, had the kick step TÜV certified. We're ready now. **Are you ready?**

1. We do it eco!

2. We do it slim!

3. We do it together!



CONSERVE RESOURCES

SAFETY² WITH 2 COMPONENTS

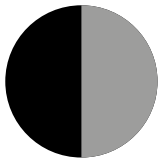

Twice the safety with 2 components or 1+1=1

We have improved the SUPERSTEP treads to make slipping practically impossible by using two components,

polypropylene (PP) and a thermoplastic elastomer (TPE), which are inseparably bonded together.

TPE is soft, but unlike rubber, highly resistant to UV rays and a wide range of weather conditions without forfeiting quality. Our steps are not bonded or pressed, but injection molded.

The body material is nevertheless 100% recyclable because both substances have the same basis and can be recycled together.



It's only 468 grams for us, but many tons for all of us.

Our keen desire to conserve resources and optimize the shape of our SUPERSTEP kick step once more was the impetus to shave off every excess gram.

At the end of the day, it was exactly 468 g. And that's quite a lot when you consider the total number of kick steps produced and sold.



Optimising the weight, shape and packaging has enabled us to increase our previous pallet load by 40%.

Our kick steps are largely manufactured using green electricity. Our packaging is made of cardboard and is 100% plastic-free.

Of course, we have not compromised on the quality of our packaging. We want you to continue to receive our product undamaged.

Prod. code: 212 3XX
MADE IN GERMANY
FACTS:

Material: PP and TPE

Colors: white, light grey, anthracite,
red, blue, black

Weight: 2.15 kg
Base/ring diameter: 42.4 cm
Top diameter: 29.2 cm
Height: unloaded 42.8 cm, loaded 41.5 cm

Certification: TÜV and GS
WEDO® warranty on the body: 10 years

Delivered pre-assembled, incl. fitted, spring
loaded smooth-running castors.
Simply join the top and bottom parts.

In a ready-to-ship box.



Art.-No. 212 300



Art.-No. 212 337



Art.-No. 212 312



Art.-No. 212 302



Art.-No. 212 303



Art.-No. 212 301

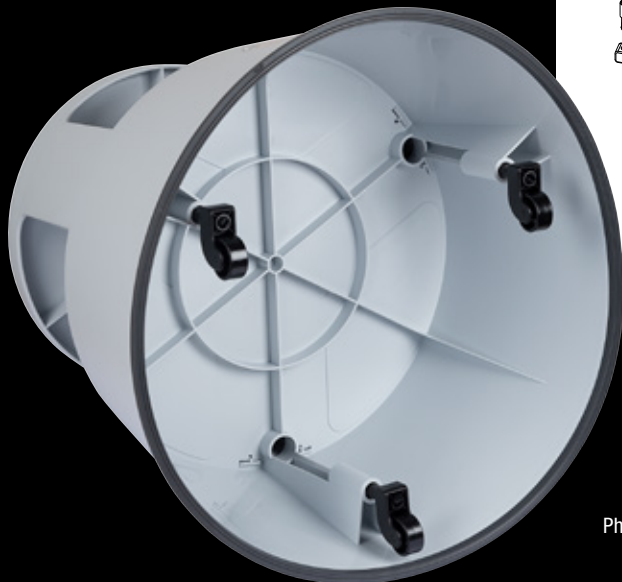
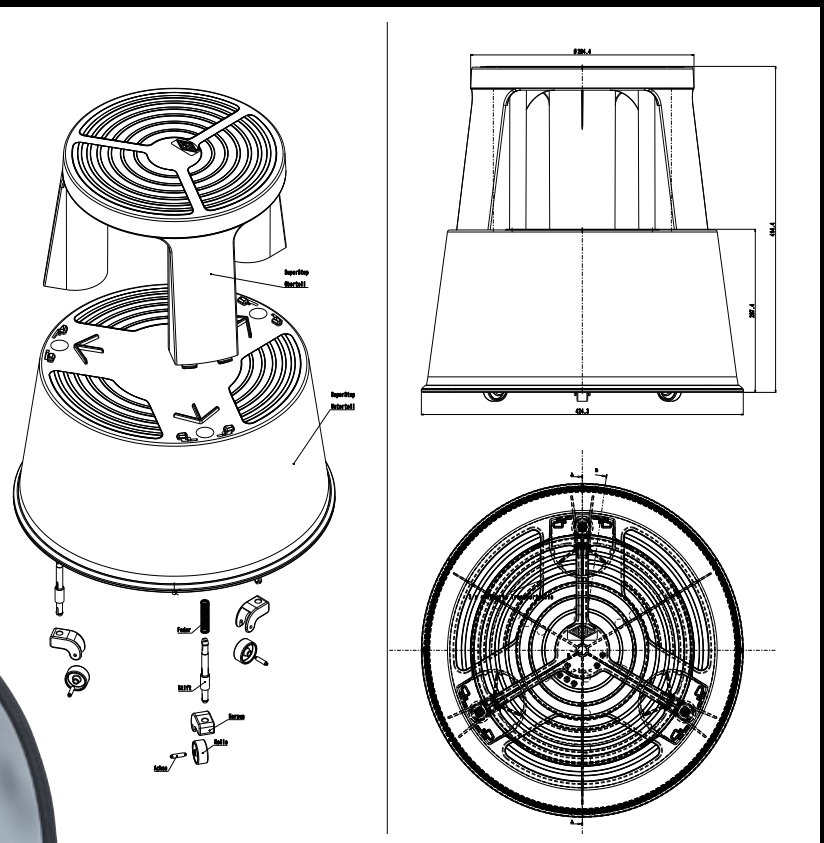

Werner Dorsch GmbH
Dieselstraße 13
D - 64 807 Dieburg
Phone +49 (0) 6071 967 - 0
www.wedo.de